

Akor Option 1 - Cold Loft Installation

WHOLE-HOUSE VENTILATION WITH HEAT RECOVERY



Recent major advances in heating and insulation systems have produced substantial increases in the general standard of home comfort. These advances have, however, brought problems of their own:

CONDENSATION is the most evident. Inside a modern well-insulated building, the air is trapped. Moisture is added to the air continuously by "wet" activities such as showering, bathing and cooking. Even a single person's breathing adds about one litre of moisture each day.

The results of condensation take various forms, ranging from the minor inconveniences of misty mirrors and windows, to the costly and substantial damage caused by mould growth on walls and ceilings. A less obvious, but even more expensive and serious result of condensation is rapid deterioration of building structural elements.

STALE AIR is the result of the lack of air change within the building. Apart from being unpleasant, stale air is unhealthy. This is a particularly important point, in view of the current increase in levels of asthma and other respiratory disorders.

THE SOLUTION is proper ventilation. In the past, this has meant fitting extractor fans in the kitchens, bathrooms, toilets and other "wet" rooms of the home. This approach, however, is only a partial solution, since it fails to ensure controlled and effective air changes for ALL rooms. The fans are unsightly, noisy, and they waste heat. In most cases, they are only switched on for short periods, and hardly ever at night when condensation is at its worst. In many homes, the extractor fans are never used at all.

The British Standard Code of Practice for the control of condensation in buildings, BS 5250, states:

"The ideal ventilation system would extract air from the moisture-producing areas to outside, and replace it with fresh air flowing in via the other rooms. This would reduce the amount of moisture at source, prevent its spread, and ventilate the whole building with fresh air."

An **HRV** installation provides a **continuous** low rate of air change throughout every room in the house. The air-change rate can be increased when necessary, for example, while cooking or showering. And there's an added bonus: the **HRV** helps to cut heating bills as it can recover more than 70% of the heat contained in the air which is drawn out of the house.

HRV comprises two fan systems. The **extract** system removes air from the wet rooms of the house - kitchens, bathrooms, utility rooms, etc. - and exhausts it to the atmosphere outside the house. The **supply** system brings in fresh air from the outside, warms it with heat from the extracted air, and delivers it to the lounge, dining room, bedrooms and other dry rooms.

HRV moves air continuously at a very low speed, providing a steady flow of air through the house - in at the dry rooms, and out at the wet ones. Stagnant, stale air is eliminated and, since moist air is extracted near its source, moisture cannot spread to other parts of the home. Also, because **every room** is served, there are no pockets of still air where condensation might form.

The **heat exchanger** is the point at which the inlet and exhaust air flows cross - without ever coming into contact with each other. Only heat is transferred from the warm outgoing air to the cool incoming air. Smells, cigarette smoke and other contaminants in the stale exhaust air can never reach the clean fresh air entering the house.

With any whole-house ventilation system the airflow through the inlet and extract valves must be accurately controlled to suit the rooms in which the valves are sited. If this is not done properly, the system could produce draughts in some rooms, while leaving others with an inadequate airflow.

In most systems, flow control and balancing are achieved by adjusting the valves mounted in the various rooms. Often, this is a very hit-and-miss process and, even if the settings are originally made correctly, they are an altogether too attractive target for later tampering by "helpful hands"!

In the **HRV** system, all flow control and balancing problems have been eliminated. Flow control valves are fitted on the central unit itself, and are designed so that, once installed, they provide the required flow rate without any further adjustment.

PLANNING YOUR HRV INSTALLATION

Planning your own **HRV** installation is easy, provided that a few simple guidelines are followed. You will achieve the most economical and satisfactory results if you work step-by-step through the following stages.

1) DECIDE ON THE LOCATION FOR THE CENTRAL UNIT

Choose a position, usually in the loft, near to the centre of the house. This will give the shortest and, therefore, the least expensive ducting runs. Make sure that the chosen location allows access for servicing the **HRV** unit. The maintenance required is minimal, but the fans, filters and the heat exchanger need occasional cleaning to maintain peak efficiency.

Put a thick layer of mineral wool (or similar material) under the **HRV** unit & place on a firm base. This minimises any chance of noise transmission through joists, etc. Do not use rigid board such as Kingspan or Celotex.

Electrical requirements are a fused (**2 amp**) spur adjacent to the unit and five cores (from the unit to the control switch). If an electrical preheater is fitted 6 cores will be required.

2) PLAN THE AIR INLET AND EXHAUST ROUTES

The fresh air inlet and the stale air exhaust of the HRV both use 150 mm ducting. They may be routed through the roof, a wall or a soffit. In windy situations, don't site the inlet or outlet on a wall, which faces the prevailing wind. Keep the inlet and outlet well apart to avoid any cross-contamination of the airflows.

3) REMEMBER THE BASIC RULES OF DUCTING

Avoid sharp bends wherever possible, as they can affect efficiency. The ducting supplied is flexible, and can be shaped smoothly around bends. Avoid sharp bends and ensure that the flexible ducting is pulled as tight as is practical. Avoid internal corrugations in the duct if at all possible as they will have a detrimental effect on the airflow, impair efficiency and possibly create a noise problem. Where a sharp bend is necessary, cut the duct & fit a rigid PVC bend.

When the ducting runs between floors, use fitted cupboards, airing cupboards etc. to hide it. If this is not possible, run the ducting in a corner where it can be boxed-in unobtrusively. Check the direction in which the floor joists run. Where a valve is fitted through the ceiling of a room, the direction of the joists will affect the route chosen for the ducting.

4) PLAN YOUR EXTRACT SYSTEM

Decide on the rooms to service. The HRV will extract from up to seven rooms, but it is not necessary to use all the extract points. Surplus points are blanked off and allow for future alterations or expansion. Remember that for each extract duct there is complete control over the rate of airflow. Try to balance the system with approx. 2 supply points for every extract. If there is a significant imbalance, swap an inlet valve for an extract, or put in extra inlets.

Decide on the position of the kitchen extract valve. This should be fitted in the ceiling between the sink and the cooker. If a separate cooker hood is fitted, the best alternative location is over the sink.

Choose the extract rate for the kitchen. The kitchen extract point uses a 125 mm duct, and the associated valve on the central unit has two settings. The "small kitchens" setting gives an extract rate of 55m³/hr at normal speed, and 120m³/hr at boost speed. The corresponding figures for the "large kitchens" setting are 55m³/hr and 135m³/hr. The setting can be changed easily at any time.

Choose a position for the control switch. The kitchen or utility room allows the easy selection of boost speed when necessary.

Decide on the position of the extract valve in each of the remaining wet rooms. These ceiling-mounted valves, which are served by individual 80 mm duct runs, should be sited near to the source of moisture and across the room from the door. Choose the extract rates for these wet rooms. Three different rates are possible. With no constant-volume device (yellow insert) fitted to the extract port on the HRV unit, the rate is 50m³/hr, which is suitable for a large bathroom or utility room. With a constant-volume device fitted, the rate can be set to either 30m³/hr, for a small bathroom, shower room, etc., or 15m³/hr which would suit a small separate toilet.

Check that your selected settings give an adequate air change rate for the whole house, as described in - Section 7.

5) PLAN YOUR SUPPLY SYSTEM

The supply system is installed in a tree-and-branch arrangement. From the central HRV unit, 150 mm ducting is used to the point where the first two supply branches leave, after which 125 mm ducting is used. The individual branches to each room use 60 mm ducting.

Pairs of 60 mm branch ducts can be run from the main duct with a reducing cross fitting. The main 125mm ducts normally terminate with a fitting which has 3 x 60mm branches, some of which can be blanked off with an end cap if required. If an odd number of ducts are to be installed, a 60 mm end cap will also be required for the spare branch.

Site a supply valve in every dry room as far away from the door as possible to ensure airflow throughout the whole room. The total requirement for supply valves in most houses will normally be approximately twice the number of extract valves installed. One would usually avoid locating valves in halls or on landings, as this may interfere with the through flow of air, but may sometimes be necessary to balance supply & extract airflows.

The valves are square, with openings on three sides only. This allows positioning close to a wall with the closed side nearest the wall so as to avoid down draughts or discolouration of the decoration.

In houses with one large living room, rather than a separate dining room and lounge, it is advisable to install one supply valve on each side of the room. Similarly, any large room may have more than one valve.

6) MAKE PROVISION FOR THE CONDENSATION DRAIN

Every heat exchanger produces a small amount of internal condensation. In the HRV unit, a small plastic tube drains this water. Connect this to any convenient waste outlet ensuring that there is a 'U' bend in the pipe, or to a soil vent pipe using a U waste fitting and ensure that this is filled with water to prevent the HRV unit from drawing in foul air through the condensate drain pipe.

7) CHECK THE TOTAL AIR CHANGE RATE

The required air change rate in any house depends upon the number of people who live in it, and the uses to which they put it. A house with a single occupant will produce very little moisture, for example, compared with a house occupied by four or more adults, particularly if someone is at home all day. Likewise, the amount of cooking, bathing and showering will greatly affect the amount of moisture produced.

In practice, the required air change rate for almost all homes falls in the range 0.5 to 1.0 changes per hour. Most homes are close to the lower limit, and only in the most demanding circumstances is the upper limit approached. It is a good idea, before installing your HRV system, to check how the capacity of your ventilation system compares with these figures.

For Example.

A typical 3/4-bedroom detached house has a total habitable floor area of around 200sq m.

For whole house ventilation, Building Regulations state that the minimum ventilation rate should not be less than 0.3 l/s per m² of internal habitable floor area (this includes each floor, e.g. for a two-storey building, add the ground and first floor areas).

This figure is equivalent to 1.08 m per hour per m²

Therefore a house of 200 sq m. would require a ventilation rate of 216 cu.m/hr (200 x 1.08), with a recommended boost capability of 125% = 216 x 1.25 = 270 c.m/hr

This is based on two occupants in the main bedroom and a single occupant in all other bedrooms. This should be used as the default value. If a greater occupancy is expected, then add 4 l/s per occupant. (14.4 cu.m/hr)

The maximum extract rate of a single HRV unit depends, to a certain extent, on the number of valves connected, ducting lengths, etc., but the T3/7 has a specified maximum of 375m³/hr, while the GD model has a specified maximum of 470m³/hr.

HINTS AND TIPS

For best results, your house should be as airtight as possible so that HRV provides the entire fresh air circulation. Seal any leaky windows or external doors with draught excluders.

There should be a 10mm gap at the bottom of internal doors to allow for the circulation of air. If any doors are a tight fit to the floor, then adequate circulation of air will be inhibited.

HRV can run continuously, through the night if necessary, since this is one of the worst times for condensation. Power consumption is a very low 60-70 watts. Even at boost speed, HRV uses only 115 - 125 watts, roughly the equivalent of a single light bulb.

The system is very quiet, provided that the installation instructions are followed - for example, mounting the unit on a firm but padded base, and ensuring that there are no tight bends in the ducting. At slow speed, the sound level near an extract valve is less than 60% of that of an equivalent separate extract fan.

The heat exchanger in HRV is designed to operate in a temperature range from -10 °C to 130°C. Where the outside temperature is likely to drop to -10° C we recommend use of the Frost Protection Box to avoid damage to the heat exchanger and to boost incoming air temperature. The 500-watt preheater is automatically controlled by a thermostat and requires no additional switching.

In rooms where gas-heating appliances (other appliances which heat by combustion such as wood burning stoves and ranges) with a conventional flue are used, there must be a supply of fresh air into the room, which is adequate to supply both the appliance and the extractor. If in doubt, seek advice from the supplier of the appliance. Note that this does not apply to room-sealed appliances such as balanced flue boilers. If in doubt, ask!

Insulated ducting

The ducting arrangement is normally supplied is for a 'warm' roof installation. Warm roof construction requires the fresh air supply & exhaust duct to the exterior to be insulated in order to prevent condensation on the outside of the ducting. All other ducting is uninsulated.

If the house has a cold loft, insulated ducting will be required between the heat exchanger & where it enters the warm envelope of the house. It will only be required in the part of the building which is cold - normal un-insulated ducting is used as soon as it enters the warm part of the house. It is also advisable to insulate the inlet duct as this is likely to get very warm in the loft in summer and it is not desirable to bring warm air into the hot on a hot day. This arrangement is approximately 10% more costly than a warm loft arrangement.

Please specify which arrangement will be used as different parts of the ducting need to insulated

If in doubt, ASK!

Ring 01491 836666 for technical or installation queries.

Installation guide for Siroc Central Extract System
and
the Extract side of the Akor HR Ventilation System

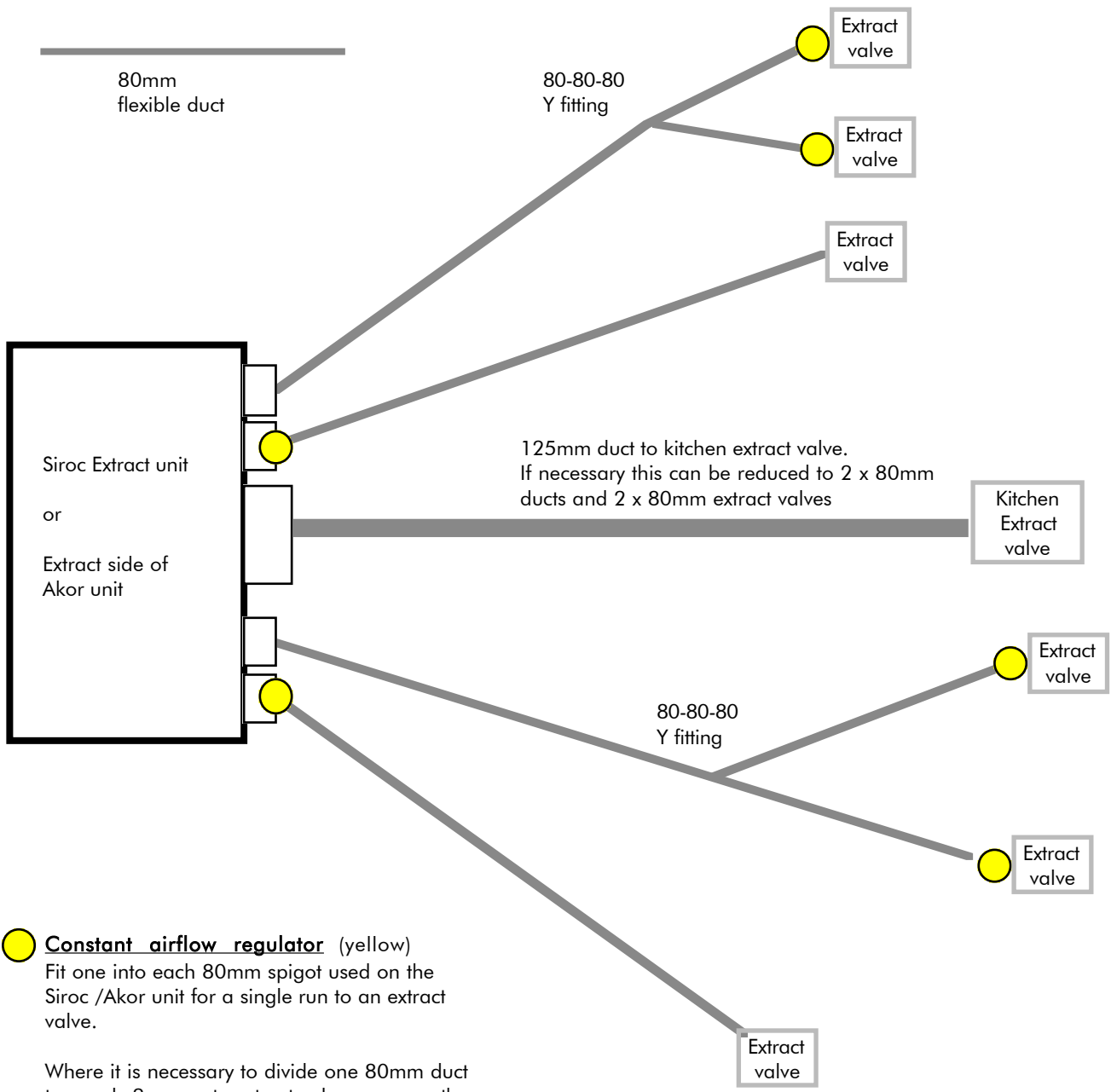

Constant airflow regulator (yellow)
Fit one into each 80mm spigot used on the Siroc /Akor unit for a single run to an extract valve.

Where it is necessary to divide one 80mm duct to supply 2 separate extract valves, remove the yellow constant flow valve from the spigot on the ventilation unit & fit this into the extract valve. Remove the cover of the valve and place regulator inside.

Airflow can be regulated by moving the (half-moon shaped) insert in the regulator. Position the insert so that the number 15 is showing for a small room (WC) and the number 30 is showing for a larger room (bathroom, shower, etc.)

Secure the flexible ducting to the fittings with the duct tape provided.

Hold the duct tape in place with the cable ties provided

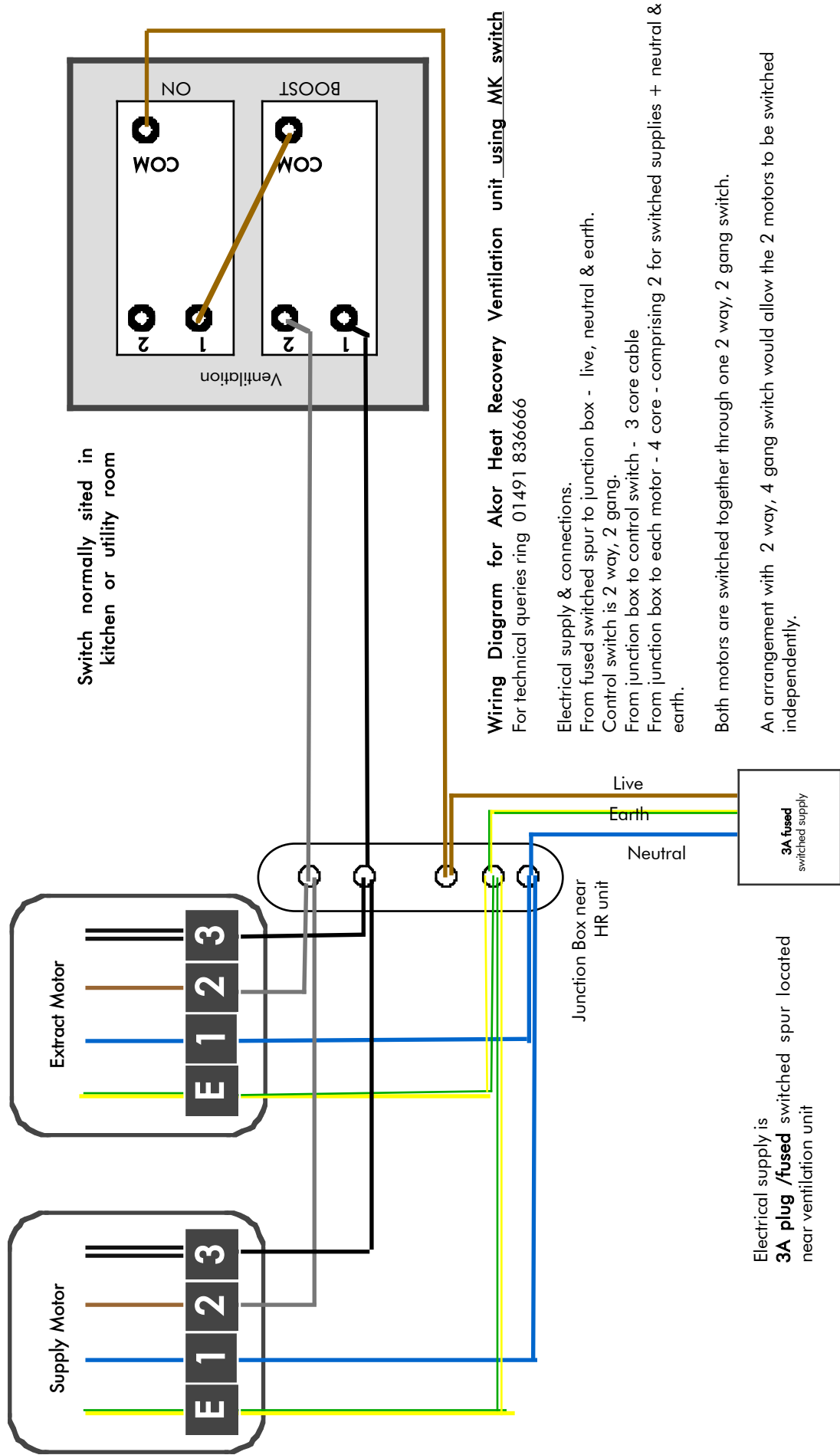

AKOR Option 1 Arrangement for Insulated Ducting in Cold Loft Installations

The arrangement shown is for HR unit installed in cold loft (or other cold area). Insulated ducting is required in the cold area - indicated by grey shading. The inlet duct should also be insulated so that it does not get too hot in summer (The exhaust ducting does not require insulating.) The efficiency of the HR unit can be enhanced by wrapping it in Rockwool or similar.

-  Ducting for Exhaust
-  Ducting for Fresh Air Inlet
-  Extract Ducting
-  Supply Ducting
-  Air Supply Point
-  Air Extract Point

Extract from 'wet' rooms

Extract ducting - typically 4 x 80mm for wet rooms and 1 x 125mm for the kitchen. Each of the ducts can be split to connect to 2 ceiling extract valves.

Grey shaded area represents portion of ducting the cold area (loft). The ducting running through this part needs to be insulated.

Once the ducting passes into to warm envelope of the dwelling, standard can be used.

If in doubt, insulate. Extra insulation can be added in the form of mineral wool.

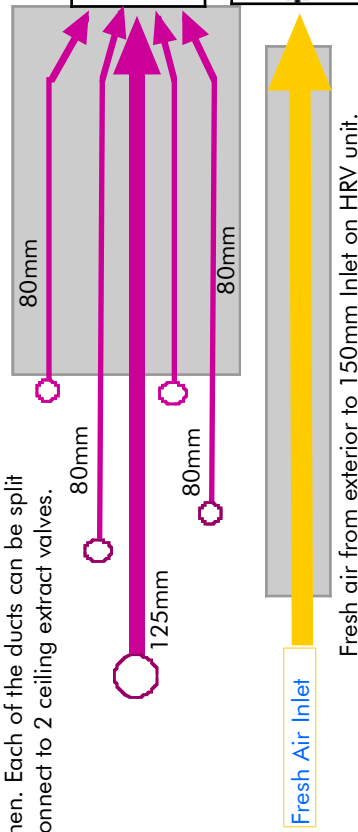

In order to minimize transmission of any motor noise, place HR unit on a thick layer of soft insulation material (e.g. mineral wool) **NOT** insulation board such as (Celotex, Kingspan).

Don't forget that a condensate drain is required from HR unit. This should pass through a 'U' bend to prevent air leakage through the drain.

NB - In all instances where insulated is used, the outer sleeve forms the air seal. It is essential that the outer sleeve is sealed at each end with a cable tie/duct tape where it attaches to a duct fitting.

Supply air to 'dry' rooms

Fresh air from exterior passes through HR unit to 150mm SUPPLY outlet on HR unit.

150mm flexible duct is reduced to 2 x 125mm ducts to run across loft & then reduced to 60mm connections. All supply ducting in a cold loft should be insulated.

60mm ducts run from here to air supply valves in individual rooms



* A 150mm 90 degree bend can be fitted to any of the spigots in order to redirect the ducting from the HRV unit

Stale air expelled to Exterior

Stale air vented to exterior via 150mm flexible duct which is usually connected to a roof vent tile with 150mm connection or 150mm wall grill (Both available from CVC Direct).

Exhaust Air